



Welcome to the European Workshop

Best available technologies & future fast progress of Micro-CHP in conjunction with Renewable Energy

- The  Team and its motivation
- The  project/ operational experiences
- Next activities
- Political and economical goals/effects



Team



s&r Berlin
R&D Fuel Cells
Controller System

TU Bergakademie
Freiberg
IWTT/HTA
R&D Reformer

DBI GUT
DBI Freiberg
R&D Burner
Certification

**Energy
Conversion
with
Fuel Cells**

UTF Freiberg
Reformer
Construction

TGZRiesa-GRH
Demonstration

BEHR INDUSTRY
Freiberg
Heat Exchanger



Cooperation with ATB Potsdam – Biogas as fuel for PEM systems with steam reformer



Cooperation with the Society for the Promotion of Renewable Energies (FEE e.V.)

Motivation

- ***Introduction of new efficient technologies to the decentralised energy market Combined heat and power production (CHP)***
- ***Development of compact hydrogen generators for natural gas and biogas for PEM fuel cells***
- ***System development of fuel cell CHP systems in the range of 4 up to 20 kW electrical power***
- ***Process optimisation of fuel cell CHP systems***

Parameters and Design of the Fuel Cell-Mini-CHP System



system inhouse4000:

reformer: natural gas steam reformer with off gas recovery
 fuel cell: PEM fuel cell
 inverter: 230 V AC/ 50 Hz

technical Parameter:

electrical power: 1,0 – 4,0 kW
 thermal power: 2,4 – 8,5 kW
 heating circuit temperature: 40/60°C
 overall efficiency: 60 - 90 %
 electrical efficiency: 25 - 30 %
 natural gas consumption: 0,5 – 1,5 m³/h
 water consumption: < 10 dm³/h

dimensions:

W x D x H: 800 x 1400 x 1600 mm

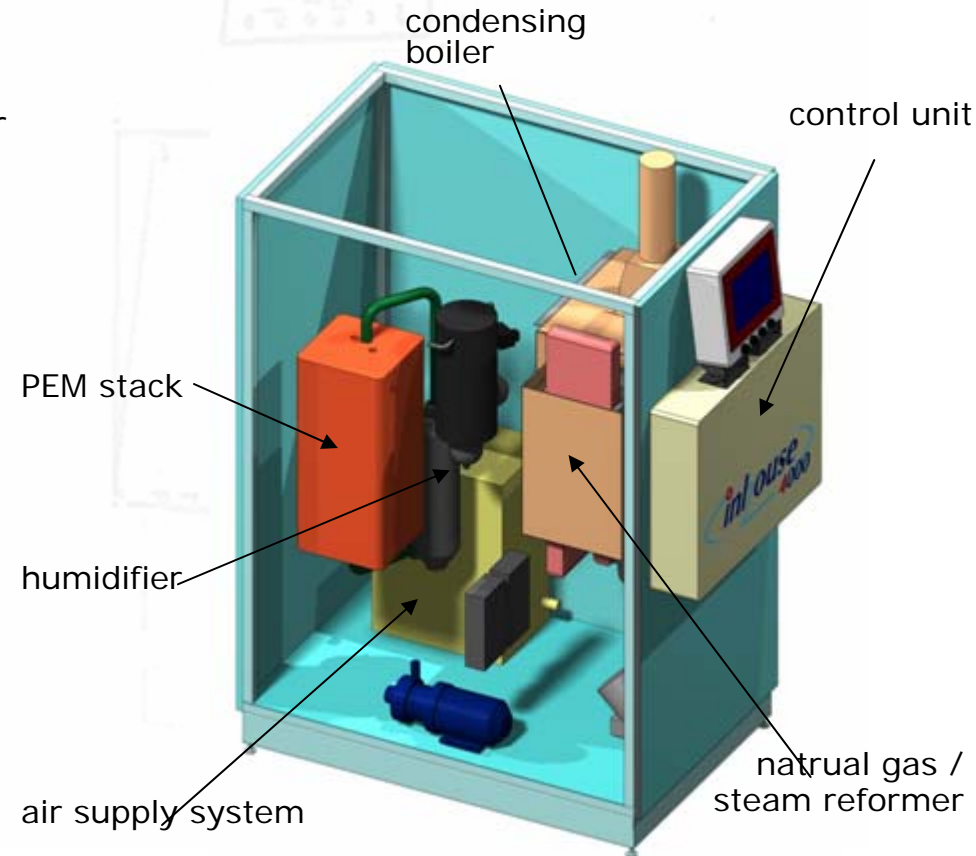

Hannover Fair April 2005

Hannover-Messe 11.-15.04.2005 :
Group Exhibit Hydrogen + Fuel Cells,
HANNOVER FAIR '05, Hall 13, G60



The **inhouse**⁺ 4000 System at the Botanical Garden in the City of Chemnitz

**2 Years Field Test within the Monitoring Project
“DemoCell”
by Verbundnetz Gas AG**

- Integration in the heating system of the Botanical Garden
- Heating circuit : 70/50 °C
- Existing central- : 2 x 250 kW heating Boiler
- Electrical Power is feeded into the electrical Grid of Chemnitz
- Test goals:
 - Determination of efficiency under real conditions,
 - Determination of dynamic behaviour
 - longterm tests



Integration in the heating system

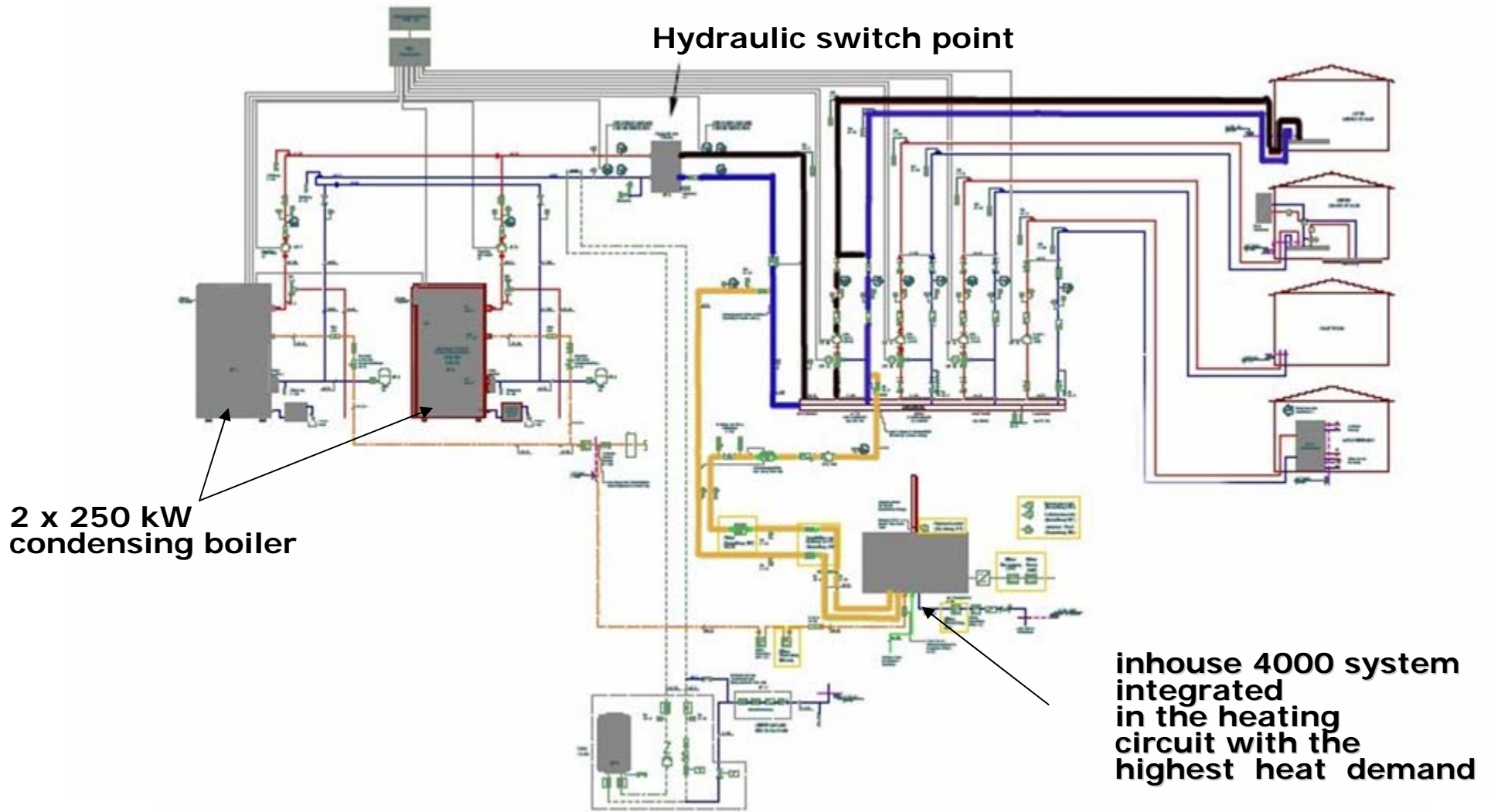

Results of the field test

- Set to operation 30.06.2005
- Test operation until 24.08.2005
- Regular field test and continuous operation from 24.08.2005
- Achieved operating parameters (28.03.2006)
 - Operating time reformer 4298 h
 - fuel cell 3101 h
 - generated electrical energy 6985 kWh
 - generated thermal energy 21491 kWh
 - Fuel consumption 41140 kWh

Operating time/ degree of efficiency

Average degrees of efficiency during operation

- Electrical 20,6 %
- Thermal 57 %
- CHP coefficient 0,36

Max. degrees of efficiency during operation

- Electrical 25,6 %
- Thermal 54,5 %
- CHP coefficient 0,47

Operating time during field test

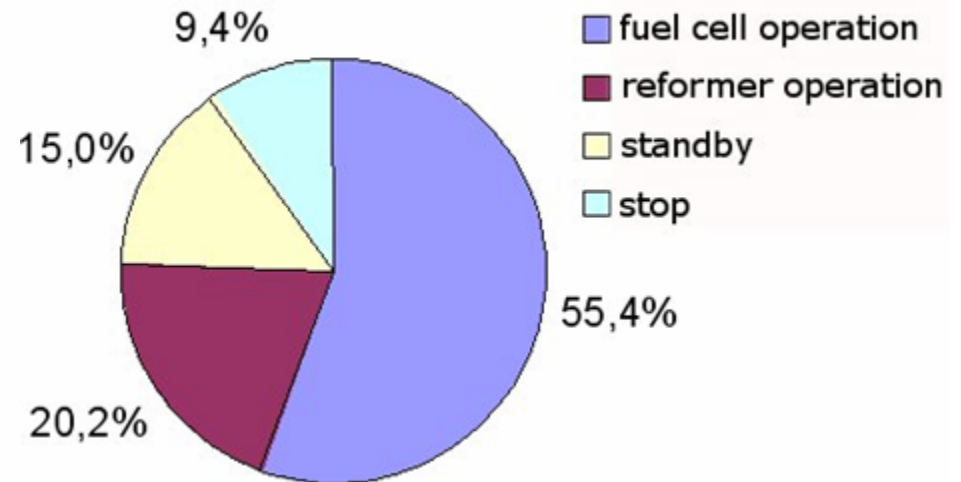

Problems during fieldtest

- Extrem variations in heating circuit temperature
 - Switching on/ off of the condensing boilers

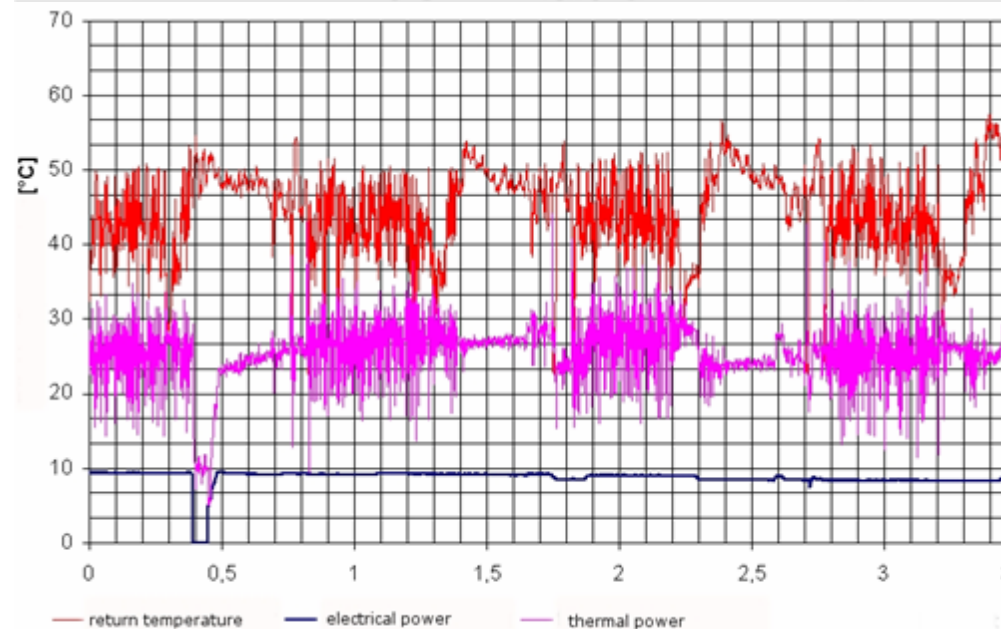

without buffer

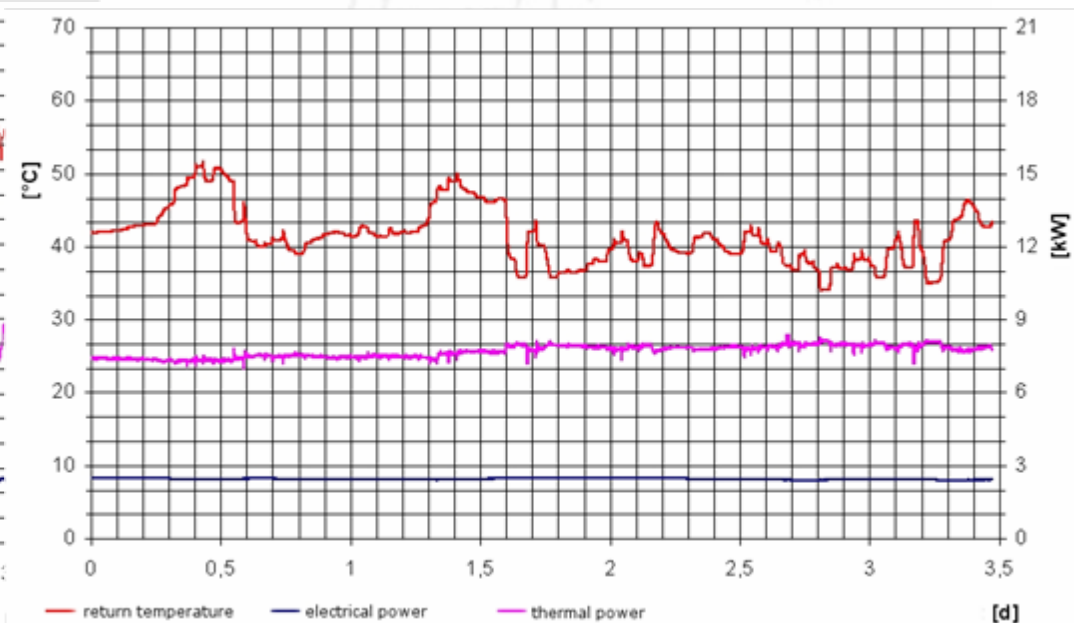

with 500 l water buffer



- Problems with peripheral systems e.g. cooling water pumps, magnetic valves

Cooperations/ Biogas activities

- 2001 start of Cooperation with ATB Potsdam
- 2003 1 kW PEM system with steam reformer operated with biogas, was set to operation
- The  system is operated with natural gas
- Development considered Biogas
- 1 kW Biogas PEM system was adapted by a 1 kW natural gas PEM System



Next Activities

- Market positioning of the manufacturing company RBZ GmbH
- Development of the next inhouse generation
- Production of  CHP systems for field tests and demonstration projects
- Continuation of R&D activities within the  Team to achieve further cost reduction and efficiency optimisation
- Implementation of high temperature PEM membranes
- Catalytic heat exchangers (reformer)
- Increased utilisation of biogas (ATB Potsdam)
- Integration of a sales partner
- Integration of new partner (EU) in the  Team



Problems and solutions

- The  Team is a corporate network of small and medium-sized companies with a small budget and national fundings.
- We are in business competition with international companies like plugpower (USA), Vaillant (Germany) , which are getting a multiple of fundings .
- To be competitive we are looking for research establishments and other european small and medium-sized companies with a high know how in special business areas.
- EU funded projects are not easy to handle for small companies
- Additional financial support by the European Commission is necessary to compensate the strong governmental support in USA, Japan, Korea and China.

Thank you very much for your
attention